

NO	DESCRIPTIONS	DIMENSION	M/T/L	QTY	REMARKS
1	UV Lamp	39W		1	
2	Balast cabinet	210*50*40	ABS	1	
3	S/W	Ø12 AC220V		1	
4	LED Lamp	Ø12 DC5V		1	
5	Line code	15A		1	
6	Cable holder	PG9		3	
7	Cap	Ø76 * 100	STS304	1	
8	Flange	65A - 10kg/cm <sup>2</sup>	STS304	6	

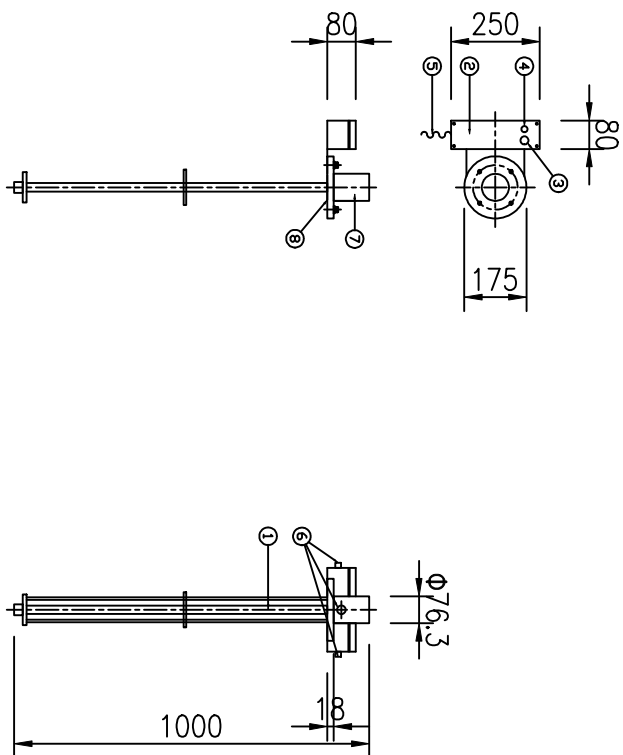

PROJECT	UV Disinfectior	DATE	2014. 01.
TITLE	HS-391T	SCALE	1/20
DRAWN	DESIGNED	CHECKED	APPROVED
SHEET NO. 00		DRAWING NO. HU-0000-000-00	



환성지외선(주)